

# CIRCULAR CONNECTORS

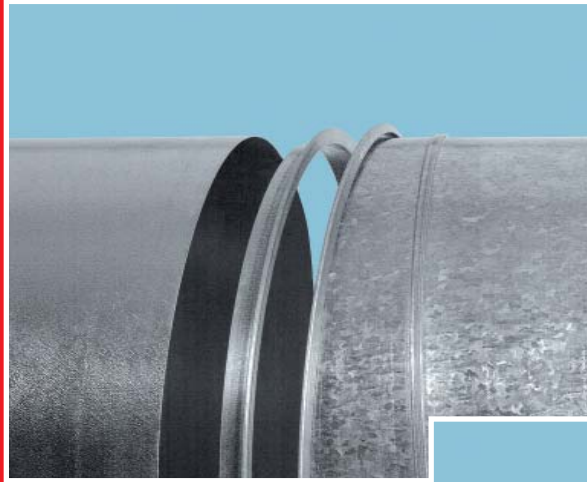

**METU<sup>®</sup>**  
**STREIMER**  
for better ductwork

# CIRCULAR CONNECTORS

## Contents:

- MF Circular Flanges Page 1
- SR Joining Clips Page 3
- MU Overcollar Page 5



- Cost effective flange connection.
- Simple profile that provides additional duct reinforcement.
- Very good air-tightness reduces the need for external sealants.
- Suitable for many different kinds of ductwork, such as spiral seam and longitudinal seam.
- SR Joining Clips are used to assemble the ducts.
- For round duct 8" to 118" in diameter.

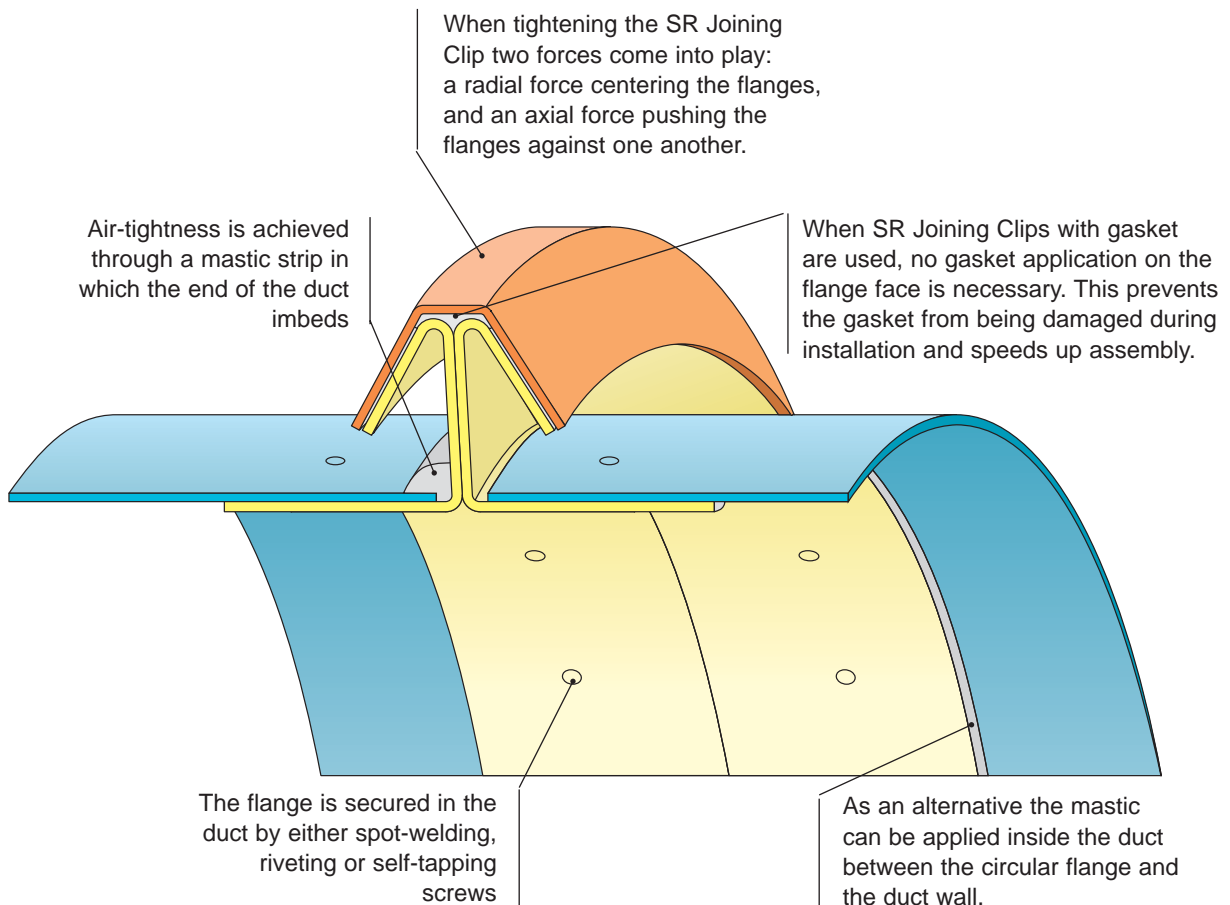

## APPLICATIONS

MF Circular Flanges are used if:

- looking to reduce overall installation costs.
- joint sealants are required

## FEATURES

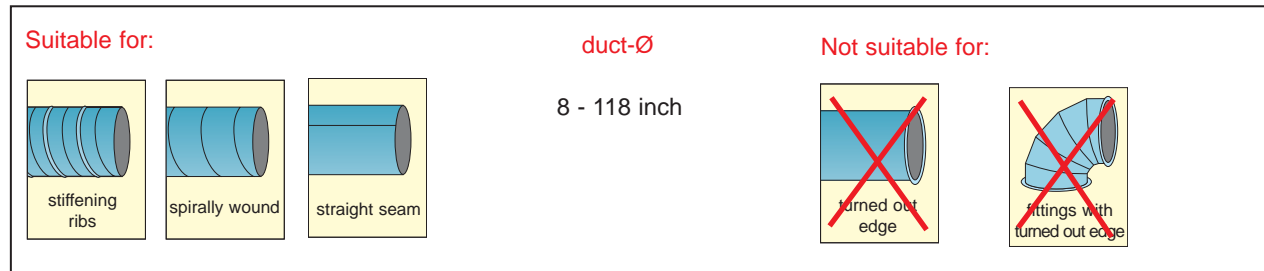
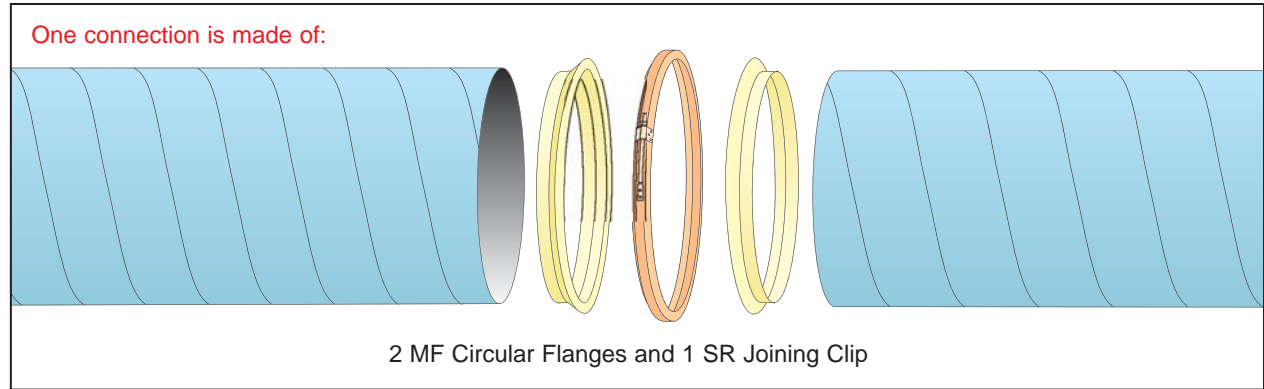

Dimensions:  
(galvanized version)

There are three MF Circular Flange profile sizes:

	MF 45 for duct-Ø 8 – 18 inch	MF 90 for duct-Ø 20 – 28 inch	MF 160 for duct-Ø 40 – 118 inch
A	.272 in.	.445 in.	.657 in.
B	.551 in.	.913 in.	1.339 in.
C	.787 in.	1.102 in.	1.654 in.
D	.039 in.	.047 in.	.079 in.
E	.197 in.	.315 in.	.433 in.



- Joining Clips enable the assembly of MF Circular Flanges.
- Allows considerable cost savings thanks to the one-bolt system.
- Available with and without gasket.
- For round duct 8" to 118" in diameter.

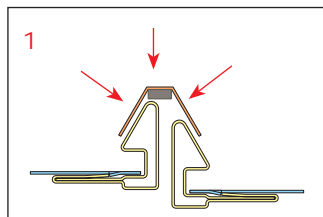
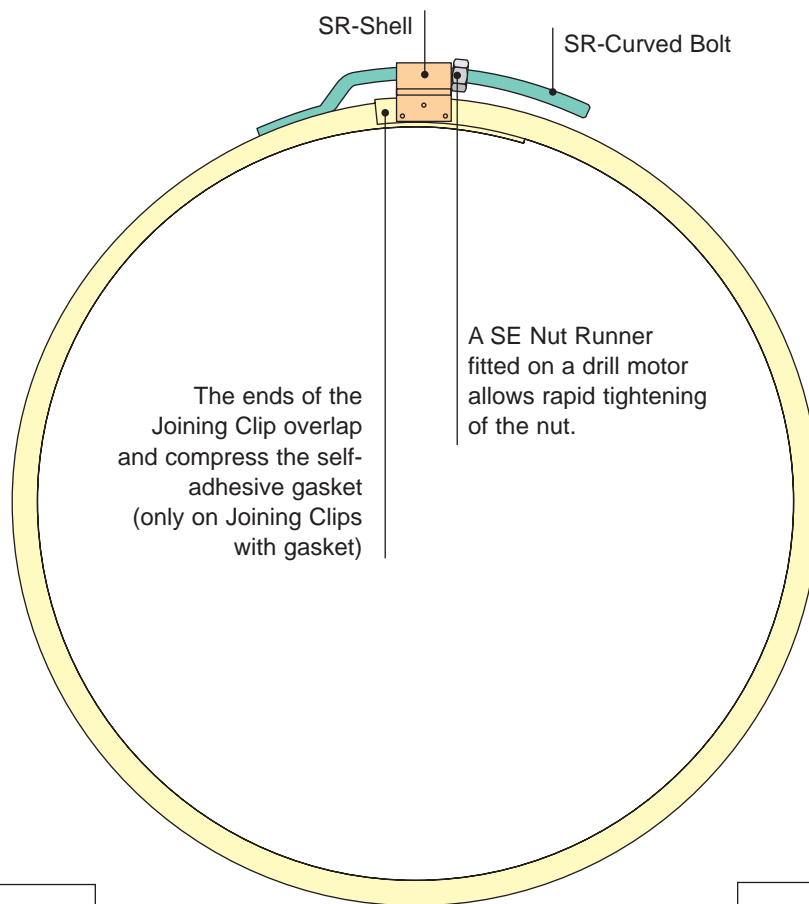

- When tightening the SR Joining Clip two forces apply:
1. a radial force centering the flanges, and
  2. an axial force pushing the flanges against one another.

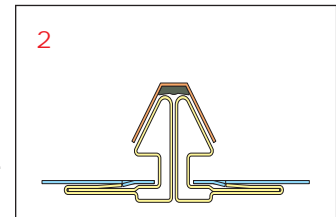

# SR JOINING CLIPS

## INSTRUCTIONS FOR JOINING (2) MF FLANGES

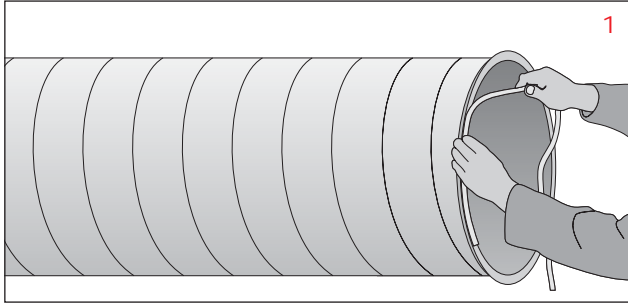

1

**Only when SR Joining Clips without gasket are used,** apply the gasket in the middle of the flange face as depicted on one of the mating flanges. The end of the gasket should butt up to the beginning.

*Gasket comes in three sizes to accommodate round diameters from 8-18 inch, 20-38 inch and 40-118 inch and is available by the roll.*

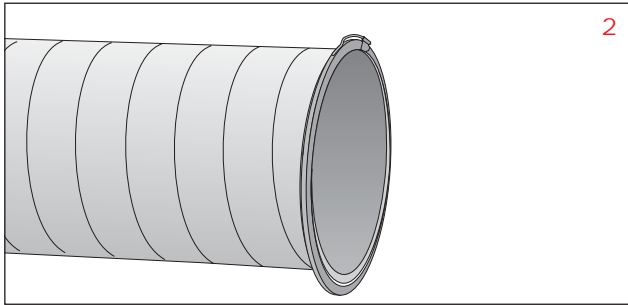

2

Take SR Joining Clip in your hand and back off nut until you are able to hang the SR Joining Clip over the flange. *Note: Do not remove nut completely.*

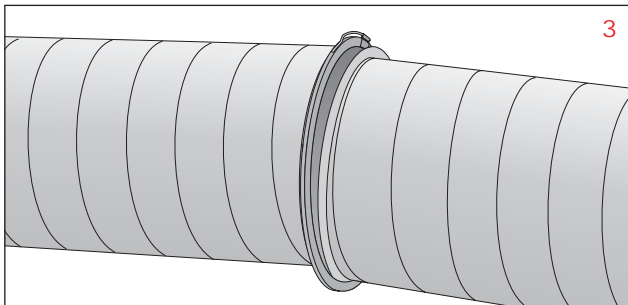

3

Insert the next duct section into the lower half of the SR Joining Clip. Continue to raise the opposite end of the duct joint until both flanges are parallel. *If needed, METU-SYSTEM alignment grips can be used to assist in this alignment process, particularly handy in vertical duct runs.*

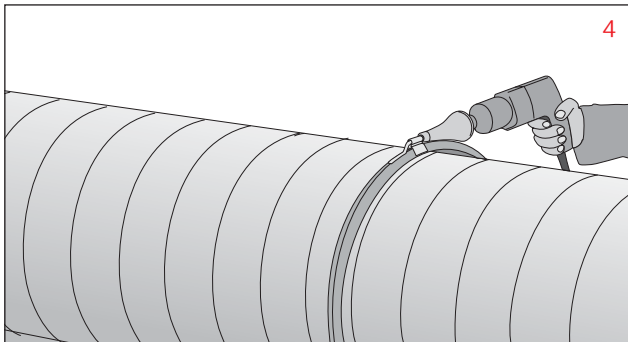

4

Finally tighten the SR Joining Clip using the correctly sized SE Nut Runner fitted on a drill motor.

Interrupt the tightening process several times and hammer the Joining Clip slightly with a rubber hammer to ensure a tight fit on the flanges.

*Please note the max. torque figures of the nut:*

SR 8-18	Galv.: 3-5 ft/lb	Stainless: 5 ft/lb
SR 20-38	Galv.: 12 ft/lb	Stainless: 14 ft/lb
SR 40-118	Galv.: 39 ft/lb	Stainless: 45 ft/lb

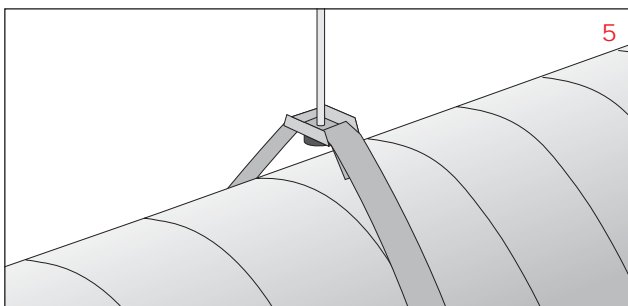

5

*BA Duct Hanger Brackets enable secure and economical duct hanging using a single 3/8" rod and 1" hanger strap.*

*This product meets SMACNA standards for use on ducts up through 36" round when installed at a maximum of 12' spacing.*

*This product is also available with and without sound isolation.*



- Economical connection for small duct diameters.
- Great device for connecting to terminal units and exhaust air valves.
- No projections inside the duct.
- A one-bolt attachment system ensures a rapid and trouble-free assembly.
- Can be easily disassembled.
- No preparation of the duct ends necessary.
- For duct diameters from 3-inch to 16-inch\*.

Standard gasket made of polyethylene foam. Other gaskets for special requirements are available upon request

The rounded ends and the angled gasket facilitate the insertion of the duct.

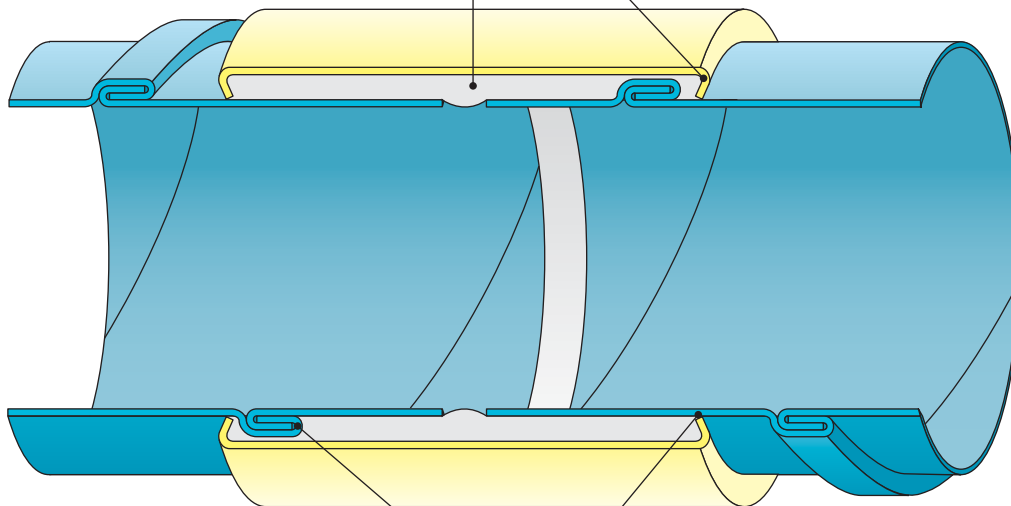

The gasket's elasticity completely seals even the external seam of spirally wound ductwork

When the MU Overcollar is tightened, the two ends of the ducting are clamped metal against metal.

(\*) 14 and 16-inch Overcollars must only be used with heavy gauge duct systems as the tightening force of the Overcollar can cause the duct to collapse if the tightening torque is not closely adhered to.

## APPLICATIONS

**Suitable for:**

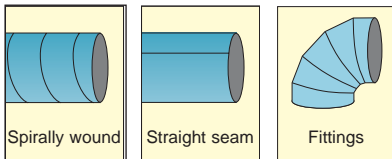

Spirally wound      Straight seam      Fittings

**Duct-Ø**

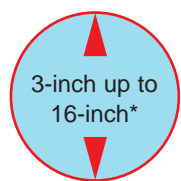

3-inch up to 16-inch\*

**Not suitable for:**

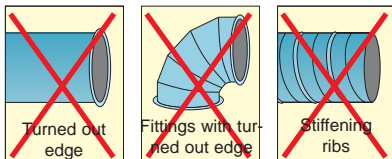

Turned out edge      Fittings with turned out edge      Stiffening ribs

(\*) 14 and 16-inch Overcollars must only be used with heavy gage duct systems as the tightening force of the Overcollar can cause the duct to collapse if the tightening torque is not closely adhered to.

**Stability:**  
When the Overcollar is fully tightened, the ductwork is held rigid, both longitudinally as well as to impede deflection or bending.

The tensile strength in the axial direction is very high. On a smooth duct wall of 4-inch duct-Ø for instance, 250 lbs. are necessary to separate the ducts. The separation force required is much higher for larger diameter ductwork and spirally wound ductwork. This rigidity is a fundamental benefit when compared with simple push-in connectors. It simplifies the installation of the ductwork while enabling considerable cost and time savings!

**Air-tightness:** Overcollars provide a simple, leak-free\* connection for round ducts.

(\*) There is a very small gap along one side of the duct seam on spirally wound ductwork which cannot be fully sealed by the gasket. To achieve higher air-tightness requirements just apply some mastic at this point along the seam.

**Drag and noise:**  
Because the duct ends are embedded in the gasket there are no projections inside the duct which could hinder the air flow. Therefore noise and dirt accumulations are avoided.

## INSTALLATION INSTRUCTIONS

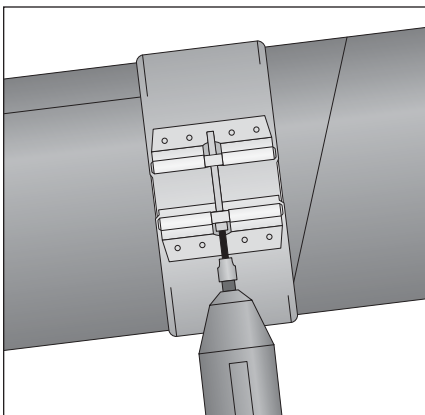

Fitting the MU Overcollar is very simple:  
Push both duct sections inside the Overcollar making sure that a distance between 1/4 inch (min.) and 1 inch (max.) is left between the duct ends. The insertion depth should be approximately the same for each duct section.

The Overcollar can be rotated before tightening the clamping bolt for esthetical or practical purposes.

Tighten the clamping bolt forcefully using a drill motor, power screwdriver or hand socket wrench until the peened over ends of the Overcollar are tight to the duct, metal to metal. The overcollar edges should be embedded into the duct seams.

Maximum torque: 4 ft/lbs

**METU<sup>®</sup>**  
***STREIMER***  
for better ductwork

Exclusively manufactured and distributed in the United States through;

**METU-STREIMER<sup>®</sup>**

740 North Knott Street • Portland, Oregon 97227-2099

Phone: 503-943-6043 • Fax: 503-288-3327

Email: [info@metu-streimer.com](mailto:info@metu-streimer.com)

**[www.metu-streimer.com](http://www.metu-streimer.com)**